 **202469**
DCC 04 V 1.0 NSLK
Inductive proximity sensor

- Highly flexible cable
- Integrated amplifier
- Short-circuit protection
- Starting pulse suppression
- LED

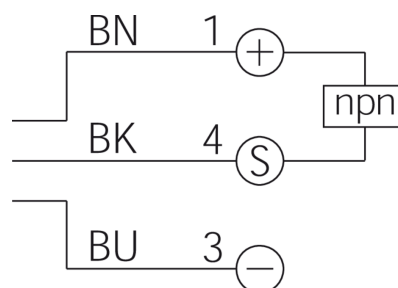
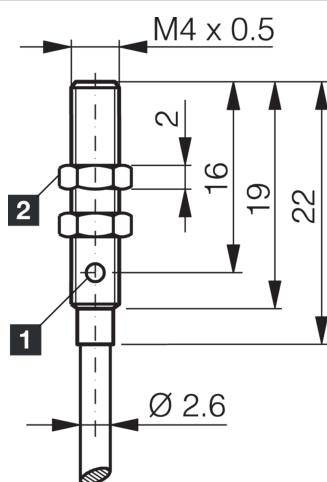
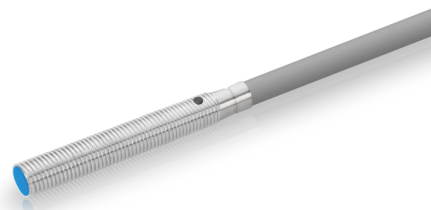

1) LED

2) Width over flats 6 mm

BK: black

BN: brown

BU: blue

Function



Technical data (typ.)

+20°C, 24 V DC

Service voltage	10 ... 30 V DC
Internal power consumption	< 10 mA
Insulation voltage endurance	According to IEC 60947-5-2 (7.2.3.1)
Installation type	Flush
Thread	M4 x 0.5
Housing length	22 mm
Housing material	Stainless steel (V2A)
Material of cable	Polyurethane
Tightening torque	0.8 Nm
Protection class	III, operation on protective low voltage
Operating principle	inductive
Evaluation	digital
Design	Thread
Characteristics	increased operating distance
Product series	INM-300 Miniature Extended
Switching output	npn, 100 mA, NO
Voltage drop (max.)	2 V (100 mA)
Switching distance (SN)	1 mm
Standardized measuring plate	4 x 4 x 1 mm
Switching hysteresis (max.)	< 10 %



202469

DCC 04 V 1.0 NSLK

Inductive proximity sensor

Technical data (typ.)

+20°C, 24 V DC

Switching frequency

3000 Hz

Ambient temperature during operation

-25 ... +70 °C

Protection type

IP 67

Connection

Cable, 2.0 m (flying leads)

More information / accessories

<https://www.di-soric.com/202469>